

Is the somitogenesis clock really cell-autonomous? A coupled-oscillator model of segmentation

Olivier Cincin

CoMPLEX and Department of Anatomy and Developmental Biology

University College London

Gower Street, London WC1E 6BT, U.K.

o.cincin@ucl.ac.uk

FAX: +44 20 7383 5519

J. Theor. Biol. **224** (4), pp459-468 (2003)

Abstract

A striking pattern of oscillatory gene expression, related to the segmentation process (somitogenesis), has been identified in chick, mouse, and zebrafish embryos. Somitogenesis displays great autonomy, and it is generally assumed in the literature that somitogenesis-related oscillations are cell-autonomous in chick and mouse. We point out in this article that there would be many biological reasons to expect some mechanism of coupling between cellular oscillators, and we present a model with such coupling, but which also has autonomous properties. Previous experiments can be re-interpreted in light of this model, showing that it is possible to reconcile both autonomous and non-autonomous aspects. We also show that experimental data, previously interpreted as supporting a purely negative-feedback model for the mechanism of the oscillations, is in fact more compatible with this new model, which relies essentially on positive feedback.

1 Introduction

Somites are transient, segmental structures in vertebrate and cephalochordate embryos, derived from

paraxial mesoderm (Saga and Takeda, 2001). They are formed on both sides by budding off anteriorly, at regular intervals (90 min in the chick, 2 hours in the mouse), from the presomitic mesoderm (PSM). Mesoderm segmentation and the polarity of the resulting somites play an essential role in the patterning of other structures, such as nerves, vertebrae, muscles and blood vessels (Keynes and Stern, 1988, Saga and Takeda, 2001).

A molecular "segmentation clock", or "somitogenesis clock", was recently identified by Palmeirim et al. (1997), and involves oscillations in both mRNA and protein levels of *c-hairy1*, a chick homologue of a gene first identified in *Drosophila*. *c-hairy1* expression is not synchronous throughout the PSM: a wave, originating from a large region of posterior PSM, spreads anteriorly while shrinking, and stabilises at the anterior border of the PSM (see below for a more detailed description). A new somite is formed every time a wave reaches the border.

Subsequently, other cycling genes were identified: *c-hairy2* (chick) / *HES1* (mammals) cycles in both chick and mouse PSM (Jouve et al., 2000), and *Lunatic fringe* (*L-fng*), an important regulator of the Notch pathway (Blair, 2000), involved in boundary formation in insect development, cycles in the chick (McGrew et al., 1998) and mouse (Forsberg et al., 1998) (but not zebrafish, Prince et al., 2001). A Notch ligand, DeltaC, was also identified as cycling

in zebrafish PSM (Jiang et al., 2000). The period of oscillation is 90 minutes for the chick, 2 hours for the mouse, and 20-30 minutes for the zebrafish (Stickney et al., 2000). In the chick, PSM cells experience about 2 cell-cycles (Primmatt et al., 1989) and 12 clock-pulses before being incorporated into a somite (Palmeirim et al., 1997).

The oscillatory expression pattern has been classified with 3 stages; in the first stage, cells in the caudal half of the PSM (youngest cells) express the genes in synchrony (or at least with much smaller phase-lags than in the rest of the PSM). In the second stage, the expression pattern moves rostrally and narrows; this narrowing was supposed by Palmeirim et al. (1997) and others (Kaern et al., 2000, Jaeger and Goodwin, 2001, 2002) to stem from a progressive increase of the clock period, but it has also been proposed that it results from shorter synthesis bursts (Cooke, 1998). In the third stage, expression becomes stabilised in one half of a prospective somite, and this somite forms shortly thereafter. Cells undergo a relative movement at constant speed in the PSM, and they oscillate about 8 times while moving from the posterior end to the middle of the PSM. When cells reach the middle of the PSM, the intensity of the oscillations in *c-hairy1* increases sharply (O. Pourquié, personal communication). For other genes such as *c-hairy2*, the intensity of oscillations is on the contrary down-regulated. *L-fng* and *c-hairy1* expression patterns are synchronous in most of the PSM, and diverge when they reach the boundary of the forming somite (McGrew et al., 1998); a stripe of *L-fng* expression stabilises in the anterior part of the forming somite in the chick, but not in the mouse.

Normal functioning of the clock seems to be essential for segmentation, as its disruption by mutations affecting the Notch pathway (Barrantes et al., 1999, Jouve et al., 2000, Jiang et al., 2000, Dunwoodie et al., 2002), or enforcement of a non-zero baseline of *l-fng* expression (Serth et al., 2003, Dale et al., 2003), result in severe segmentation defects. Different models provide a link between clock oscillations and actual somite segmentation, but our purpose here is to address the mechanism for the oscillations, rather than the way they are read out. Somitogenesis is a process which shows great autonomy; for example,

PSM explanted from an embryo still undergoes partial segmentation (even though the process requires ectoderm to go all the way, the segmental pattern is observable, Packard et al., 1993; Lash and Ostrovsky, 1986). Based on one type of experiment, the segmentation clock is generally assumed to be cell-autonomous in chick and mice (see section 3.2). However, there is also evidence that there could be some intercellular coupling in segmentation-clock oscillations (see section 2.1), as first suggested by Jiang et al., 2000 in the case of the zebrafish. The two aspects seem difficult to reconcile. In the following, we propose however a model for segmentation-clock oscillations which allows for coupling, but can also behave as if oscillations were cell-autonomous, providing a new possible explanation for experiments previously interpreted as ruling out intercellular coupling. The model could easily be extended to account for the very first segmentation clock oscillations in the primitive streak, which occur at a much earlier stage of embryonic development than PSM segmentation (Jouve et al., 2002), and which remain unexplained by current models. Oscillations in the proposed model partially rely on a positive feedback mechanism, but the model is compatible with experimental data which has been interpreted as supporting a negative-feedback mechanism, and is also compatible with experimental data which contradicts a purely negative-feedback model.

2 Lunatic fringe secretion model

Many experiments suggest that the somitogenesis clock is not cell-autonomous (see below), but some experiments have been interpreted as ruling out the existence of coupling (see section 3.2). The Lunatic fringe secretion model was formulated to resolve this contradiction, within the framework of current experimental data. The model addresses the way segmentation-clock oscillations are generated and synchronised between cells, in the primitive streak as well as in the PSM. It does not address the relationship between the oscillations, physical somite

segmentation, and polarity-establishment, but it is compatible with all major current models, which involve either the existence of a critical threshold maturity (original clock and wavefront model, [Cooke and Zeeman, 1976](#)), the spread of a signal (cell-cycle model, [Primmatt et al., 1989](#)), or an FGF8 wavefront ([Dubrulle et al., 2001](#)).

2.1 Motivation for the model: inter-cellular coupling

There seems to be some evidence that PSM clock-gene oscillations are not totally cell-autonomous:

- Primitive-streak precursors of the lateral and medial parts of a same somite do not have the same antero-posterior position in the primitive streak ([Selleck and Stern, 1991](#), [Psychoyos and Stern, 1996](#), [Eloy-Trinquet and Nicolas, 2002](#)), and the expression of their somitogenesis-clock genes does not oscillate in synchrony ([Jouve et al., 2002](#)). However, synchrony seems to be achieved quickly upon ingression into the PSM. While other complicated mechanisms could be at play, synchronisation of physically close cells seems to be the simplest explanation.
- Somites are not "developmental compartments": groups of PSM cells with a restricted spatial extent shortly after ingression can have descendants which span many somites ([Kulesa and Fraser, 2002](#)), and a single cell, labeled shortly before it is incorporated into a somite, can have descendants in two adjacent somites ([Stern et al., 1988](#)). It would be a complicated model, if oscillations are totally cell-autonomous, for daughter cells to inherit different phases after cell division, and to "sort out" at segmentation time.
- Inversion of the anteroposterior polarity of presumptive somites in the caudal PSM does not result in segmentation or polarity defects ([Dubrulle et al., 2001](#)); segmentation models relying on the somitogenesis clock require re-synchronisation of the inverted tissue with surrounding PSM for this to be possible.

- Analysis of zebrafish mutants in the segmentation-clock genes has led [Jiang et al. \(2000\)](#) to conclude that the role of the role of Notch signalling is to synchronise the segmentation clock between neighbouring cells.
- One would expect stochastic effects to have a measurable impact on the individual cellular oscillators, which could not be overcome if oscillations were cell-autonomous. Randomness in transcriptional regulation was discussed by [Kessler and Elston \(2001\)](#); phenotypic effects of varying biochemical parameters were shown by [Ozbudak et al. \(2002\)](#). Inter-cellular synchronisation was argued by [Cooke \(1998\)](#) to be necessary for the somitogenesis clock pattern to be so refined.

2.2 Biological grounding of the model

The Lunatic fringe secretion model is based on experimental data showing the crucial importance of Notch in somite segmentation, on the regulation of *L-fng* in the PSM, which shows that *L-fng* is a target of Notch activity ([Cole et al., 2002](#), [Morales et al., 2002](#), [Barrantes et al., 1999](#), [Dale et al., 2003](#)), on the action of L-fng on Notch ([Blair, 2000](#)), and on the fact that Notch receptor and ligand expression levels seem to be constant in the chick and mouse PSM ([Barrantes et al., 1999](#), [Forsberg et al., 1998](#)). It is fundamentally different from previous models of lateral inhibition mediated by Notch signalling ([Collier et al., 1996](#)), in that ligand levels are constant, and Notch signalling is periodically active in all cells. It is also very different from the clock and induction model ([Schnell and Maini, 2000](#)), in which there is no explicit molecular mechanism, Lunatic fringe is seen as a passive output, and oscillations are cell autonomous (the ratchet mechanism at the heart of that model is made very unlikely by experimental results discussed in section 3.4, which show that a non-zero baseline of Lunatic fringe disrupts oscillations).

The model accounts for coupling between cellular oscillators by secretion of L-fng, which has not been documented in the PSM, but has been in other experimental contexts ([Wu et al., 1996](#)). Notch sig-

nalling is very versatile and not fully understood, and cleavage of ligands could be involved in signalling (Artavanis-Tsakonas et al., 1999), providing another potential source of coupling; this could require oscillation of Delta levels, as has been observed in zebrafish (Jiang et al., 2000), but would not necessarily be incompatible with Delta levels being constant on a large scale, as in the chick and mouse.

The secreted factor could be different (and involve a more complex mechanism downstream of the clock) without the results presented in this section being necessarily compromised. It is also conceivable that inter-cellular communication could be mediated by gap-junctions (which do exist between PSM cells, Blackshaw and Warner, 1976); in this specific case, the structure of the model could remain the same, but the equations would probably need to be significantly modified to take into account the strong differences between ionic currents and enzyme kinetics.

2.3 Details of the model

In the following, proteins and their concentrations are denoted in the same way.

- Two forms of the Notch receptor are considered, a regular one (n), and another one (n^s), which has been greatly sensitised to Delta signalling by L-fng (l). L-fng makes Notch more sensitive to Delta signalling and less sensitive to Serrate signalling, which could make the outcome of L-fng modification of Notch uncertain if both ligands were expressed, but Serrate has been shown not to be expressed in the chick embryo up to the first somite stage (Caprioli et al., 2002). Notch is supposed to be translated at a constant rate (in the PSM, no oscillations in Notch mRNA have been shown). Because there is no evidence for oscillations in the levels of Notch-binding proteins in the mouse or the chick, Notch signalling is taken to be proportional to the quantities of Notch protein, with a weighting factor on unsensitised Notch to account for its lower efficiency. This approximates the time for Notch cleavage, for intra-cellular fragment migration to the nucleus, and for degradation of the

transcriptionally-active intra-cellular fragment, as being small compared to the period of the somitogenesis clock, so that the intensity of signalling is at a quasi-equilibrium for both sensitised and unsensitised Notch.

- Cell-cell coupling is accounted for by the action of secreted L-fng on neighbouring cells. To keep the model simple, diffusion is not explicitly considered, being replaced by a weighting factor on L-fng from neighbours (if L-fng is indeed secreted, it can probably not travel over distances covering more than a few cells). The strength of coupling is discussed in more detail in section 2.4.
- Notch drives the transcription of *L-fng*, with a cooperativity which has been chosen to be 3 (a minimum cooperativity is required for oscillations; 3 is not the minimum, as oscillations are also observed for example with a cooperativity coefficient of 2.7). Notch-dependent expression of *L-fng* is intricate, but two binding-sites for CBF1, which directly mediates Notch signalling, have been identified in the *L-fng* regulatory region (Morales et al., 2002); what's more, experimental data suggests that other such binding sites could be present (Morales et al., 2002). There is thus a basis for cooperative action of Notch on the *L-fng* gene.
- All three proteins undergo exponential decay. This corresponds to degradation which is either spontaneous or mediated by proteases functioning far from saturation.

The graph of the interactions between the components of the model is shown in Figure 1. Corresponding equations are given in Appendix A.

Although the general mathematical description of the model is given in two dimensions, only a linear chain of coupled cells will be considered in the following. Results for simulations in 2 dimensions could be in agreement with the experimentally-observed chevron of clock-gene expression (Freitas et al., 2001, Jouve et al., 2002), if one supposes that oscillations are initiated in a laterally-restricted posterior region,

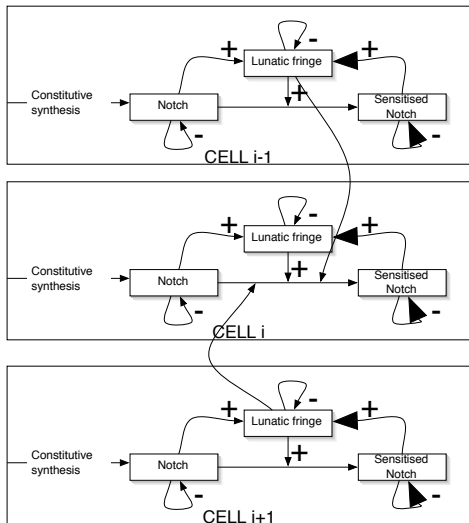

Figure 1: Interaction graph of the Lunatic fringe secretion model. For clarity, the influence of cell i on cells $i-1$ and $i+1$ is not shown.

and that lateral coupling is weaker than longitudinal coupling. One reason for the lateral coupling to be weaker than the longitudinal coupling (in or close to the primitive streak, not in the PSM), could be that only a proportion of cells are competent to oscillate; if the lateral density of such cells is lower than the longitudinal density, weaker coupling could be a crude approximation of the decreased efficiency of lateral diffusion of L-fng from one cell to another (since competent cells are more distant laterally than longitudinally). This will be addressed in a later study.

2.4 Initial phase and PSM flow

Cells stay only transiently in the PSM. This can be safely ignored when considering cell-autonomous oscillations, but a coupled system can be influenced by conditions at its boundaries, which depend on how newly-ingressed cells and freshly-segmented cells behave.

One important question is that of the initial phase of cells which ingress into the PSM. In the cell-autonomous model, that initial phase must be a complex function of time (the clock and trail model of

Kerszberg and Wolpert, 2000, also requires an oscillating initial phase). In the Lunatic fringe secretion model, it may be constant. Since the problem of synchronising newly-ingressed cells with posterior PSM is easier if these cells ingress with an oscillating initial phase (data not shown), simulations presented below were carried out with these cells taking on a fixed initial phase when they ingress.

Oscillations in anterior-most cells were stopped on arrival of an expression wave, with a crude, artificial algorithm (the Lunatic fringe secretion model does not seek to address the mechanism by which cells segment). Cells which had segmented were considered not to influence other cells any more, and their oscillatory phase was blocked.

One important aspect of somitogenesis clock oscillations is that the posterior half of the PSM should keep oscillating in near-synchrony (and that the region of synchrony should not extend anteriorly, beyond the middle of the PSM). To reproduce this, it had to be assumed that coupling was stronger in the posterior half of the PSM. This could be an indirect effect of different cell densities in the anterior and posterior halves of the PSM. Alternatively, it could be that FGF8 has the effect of making coupling stronger (FGF8 has been shown to be expressed much more intensely in posterior PSM than in caudal PSM, Dubrulle et al., 2001); this would also explain why the caudal-like domain of clock-gene expression can be extended anteriorly by grafts of FGF8 beads, as shown in Figure 4L by Dubrulle et al. (2001). Stronger coupling in posterior PSM could explain why this region is labile with respect to its segmentation programme, while anterior PSM is not. The effects of FGF8-beads grafts could also be explained by effects on the coupling strength, which will be addressed in a later study.

Simulations were performed with coupling being three times stronger in the caudal PSM than in the rostral PSM, the coupling strength being a continuous but sharp function of the relative position in the PSM (see Appendix A for details). The coupling strength needs not be a continuous function, but this was deemed more biologically realistic.

3 Simulation of the model

3.1 Reproduction of the somitogenesis clock pattern

The pattern of oscillatory gene expression, as first described by (Palmeirim et al., 1997), can be readily reproduced with the Lunatic fringe secretion model: the posterior half of the PSM can oscillate in near-synchrony, with each wave of expression travelling anteriorly (see Figures 2 to 4, and Movie 1). It is not straightforward to model the shrinkage the wave of expression as it travels; rather, a small domain of roughly constant size travels anteriorly from the region of near-synchrony.

Note the difference in intensities of Lunatic fringe expression between the anterior and posterior parts of the PSM, which is compatible with experimental data, and does not require a specific mechanism as in the cell-autonomous case.

The way the system works seems to be the following: the coupling in the model seems to reduce the oscillation period, as L-fng provided by neighbours prompts earlier firing (secreted L-fng acts both cell-autonomously and on neighbouring cells, and it is thus possible for an isolated cell to show oscillating expression of clock genes). The stronger coupling in the posterior PSM has two effects. Firstly, its cells tend to fire earlier than those in the anterior PSM (with the right initial conditions). Secondly, cells in the posterior PSM fire more in synchrony than those in the anterior PSM. A wave originated in the posterior PSM travels to the anterior PSM, but more slowly, because of the reduced coupling. It is crucial that L-fng is involved in a positive feedback circuit (with Notch signalling), so that a cell which is firing recruits its neighbours.

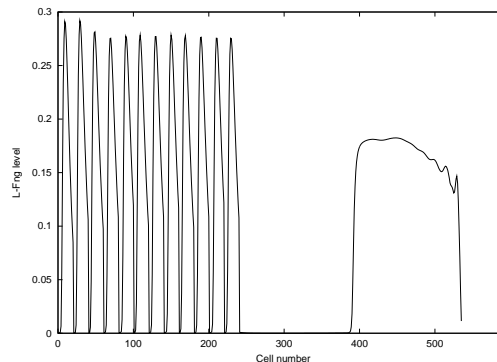
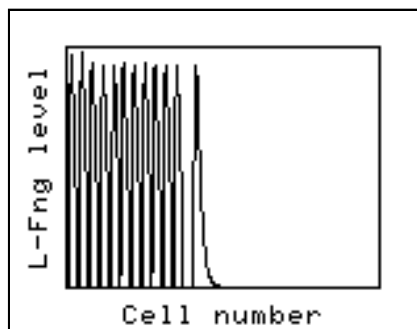

Figure 2: Phase 1 in the Lunatic fringe secretion model: a wave of expression initiates in the posterior half of the PSM. Abscissae correspond to cell number in the PSM (anterior is to the left, posterior to the right), and ordinates to L-fringe expression levels (in arbitrary units). At the anterior end, 12 somites have already formed, and their oscillation phase is frozen.



Movie 1, corresponding to Figures 2 to 4.

3.2 Discontinuities in the PSM

Experiments which have been interpreted as proving that somitogenesis clock oscillations are cell-autonomous consist in cutting the PSM transversally, and observing that oscillations continue in both halves for up to two cycles (Palmeirim et al., 1997, McGrew et al., 1998, Forsberg et al., 1998). Within the framework of the Lunatic fringe secretion model,

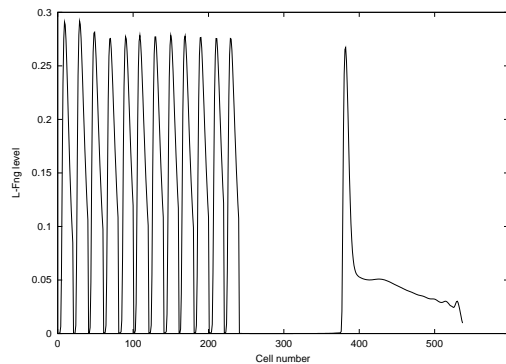

Figure 3: Phase 2 in the Lunatic fringe secretion model: the wave of expression now has a much more restricted extent and is travelling anteriorly. Abscissae correspond to cell number in the PSM (anterior is to the left, posterior to the right), and ordinates to L-fringe expression levels (in arbitrary units).

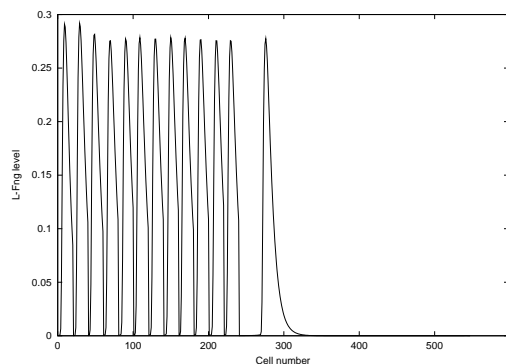

Figure 4: Phase 3 in the Lunatic fringe secretion model: the wave of expression reaches the anterior border of the PSM. Abscissae correspond to cell number in the PSM (anterior is to the left, posterior to the right), and ordinates to L-fringe expression levels (in arbitrary units).

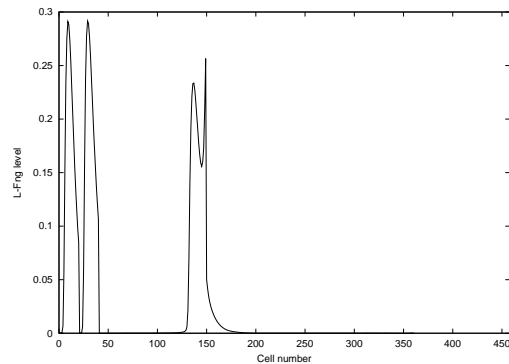
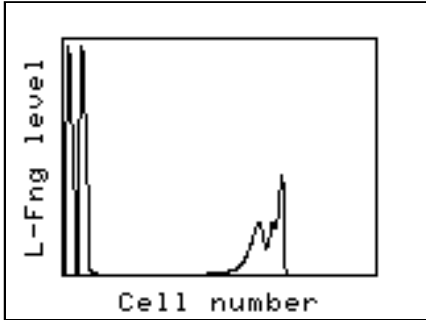

Figure 5: 2 cycles after the introduction of the coupling boundary at cell 150, the disruption of the pattern is minimal. An anomaly is only observed at times when the wave of expression reaches the coupling boundary. Abscissae correspond to cell number in the PSM (anterior is to the left, posterior to the right), and ordinates to L-fringe expression levels (in arbitrary units).

these experiments can be modelled as introducing at some time a coupling boundary in the chain of oscillators, across which oscillators do not influence each other. Simulations have been performed (see Movie 2), which show that the oscillatory pattern is essentially unaffected for many cycles after the introduction of the boundary (see Figure 5 for a snapshot 4 cycles after the introduction of the boundary). The disruption becomes larger with time, but current experimental data does not allow verification of whether this actually happens, as tissues were fixed after at most two cycles of oscillation.

3.3 Stochastic perturbations

Similar random perturbations were applied during simulations of the Lunatic fringe secretion model, and of the model given by J. Lewis as supplemental data to the article by [Palmeirim et al. \(1997\)](#), which considers cell-autonomous oscillations (see Appendix D for simulation details). Results are shown



Movie 2, corresponding to Figure 5.

in Figures 6 to 8 (see Movies 3 and 4 for a complete time-animation). With the Lunatic fringe secretion model, the overall pattern is totally preserved; some variations of expression intensity can be observed in the caudal PSM, but the different phases of oscillation can still be sharply distinguished (Figures 7 and 8). In the case of the cell-autonomous model (Figure 6), stripes of expression corresponding to already-segmented somites are discernable, but levels of Lunatic fringe are extremely heterogeneous in unsegmented PSM.

The model is also robust against parameter variations, as discussed in section B.

3.4 Effect of *L-fng* misexpression

It has been observed by Dale et al. (2003) that constitutive misexpression of *L-fng* in the PSM blocks the somitogenesis clock, and suppresses the expression of endogenous *L-fng*. This has been interpreted by the authors as supporting the existence of a negative feedback circuit between *L-fng* and Notch signalling: Notch signalling would activate *L-fng* transcription, and *L-fng* would down-regulate Notch-signalling; this circuit would be the core of the somitogenesis clock. However, while it has been demonstrated that *L-fng* transcription is indeed activated by Notch signalling (Cole et al., 2002, Morales et al., 2002, confirmed by other means by Dale et al., 2003), *L-fng*-induced down-regulation of Delta-mediated Notch signalling is contrary to present biological evidence, which shows *L-fng*-catalysed glycosylation to make

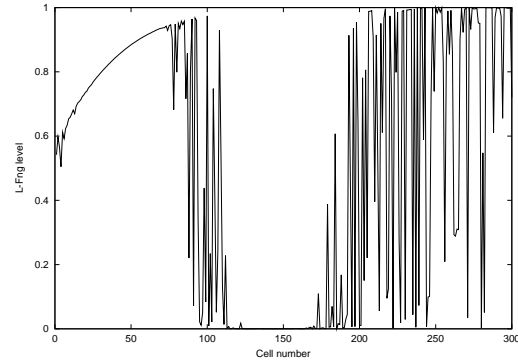
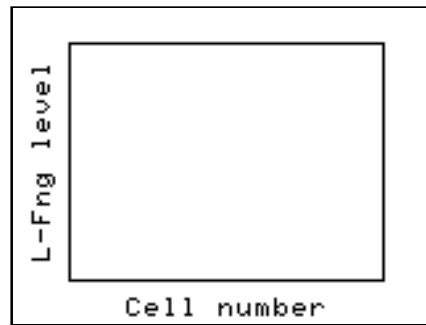

Figure 6: Simulation of the cell-autonomous model proposed by Palmeirim et al. (1997), with random perturbations in the phase of each cell. A pattern in unsegmented PSM is barely discernable. Abscissae correspond to cell number in the PSM (anterior is to the left, posterior to the right), and ordinates to L-Fringe expression levels (in arbitrary units). The model was originally proposed for *c-hairy1* oscillations, but L-Fringe oscillates with the same pattern.



Movie 3, corresponding to Figure 6.

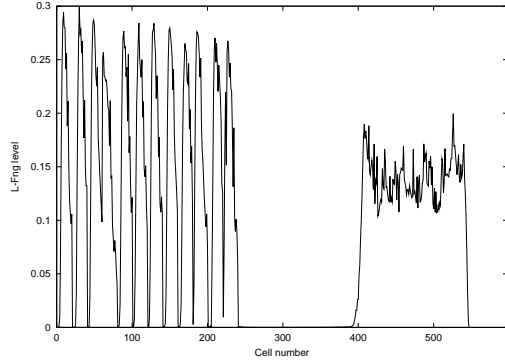
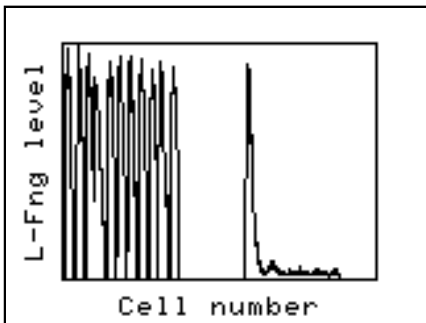

Figure 7: Phase 1 in the Lunatic fringe secretion model, with random perturbations: the pattern is still very similar to that shown in Figure 2. Abscissae correspond to cell number in the PSM (anterior is to the left, posterior to the right), and ordinates to L-fringe expression levels (in arbitrary units).



Movie 4, corresponding to Figure 7 and 8.

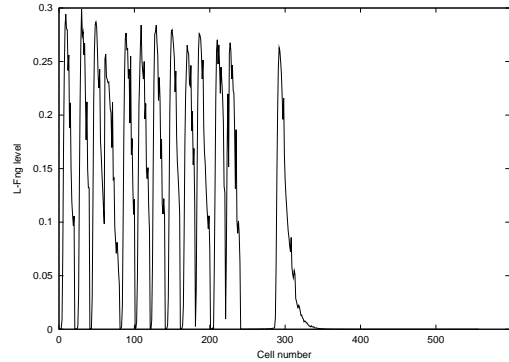

Figure 8: Phase 2 in the Lunatic fringe secretion model, with random perturbations: the pattern is still very similar to that shown in Figure 3. Abscissae correspond to cell number in the PSM (anterior is to the left, posterior to the right), and ordinates to L-fringe expression levels (in arbitrary units).

the Notch receptor *more* sensitive to activation by Delta (Blair, 2000) (of the two Notch ligands Delta and Serrate, only Delta is expressed in the chick up to the first somite stage, Caprioli et al., 2002).

What's more, suppression of endogenous *L-fng* expression by misexpression of *L-fng* does not imply that the oscillations rely exclusively on a negative-feedback circuit. In the *L-fng* secretion model, for a single cell there are 4 feedback circuits between the 3 variables, one of which (between *L-fng* and sensitised Notch) is positive and essential for the oscillations. If the model is modified to account for misexpression of *L-fng*, and if the misexpression strength is above a threshold, oscillations are stopped and *L-fng* is endogenously expressed at a dramatically lower intensity (data not shown). The intuitive reason for this is that continuous *L-fng* expression depletes the pool of un-sensitised Notch; in the model, sensitised Notch has a shorter half-life than Notch, and even though it is continuously produced if *L-fng* is continuously expressed, its concentration is much lower than its peak concentration when it is produced in bursts.

The *L-fng* secretion model is thus compatible with

the data reported by Dale et al. (2003), as well as with the data on sensitisation of Notch by L-fng.

In contrast to Dale et al. (2003), Serth et al. (2003) reported that misexpression of L-fng in mouse PSM does not suppress endogenous oscillations, but disrupts their pattern. A major difference between the method employed by the two groups is that Dale et al. (2003) electroporated plasmids carrying *l-fng* under the control of a strong, constitutive promoter, while Serth et al. (2003) created transgenic mice with *l-fng* under the control of a portion of the *delta* promoter. It is thus quite possible that a stronger level of misexpression was achieved by Dale et al. (2003). The L-fng secretion model can reconcile both results, because suppression of endogenous oscillations is only achieved above a threshold level of misexpression, comparable to the amplitude of endogenous oscillations; what's more, the amplitude of the endogenous oscillations is reduced by misexpression, as reported by Serth et al. (2003) (however, it was not possible to reproduce the disappearance of oscillations specifically in the anterior PSM).

4 Conclusion

The Lunatic fringe secretion model can account for the oscillatory gene expression pattern exhibited by the PSM of chick and mouse embryos. It is dependent on local coupling between cells, which allows it for example to not require new cells to ingress into the PSM with an oscillatory initial phase, and to be more resistant to random perturbations. However, oscillations also have an autonomous character, in that the introduction of a coupling boundary at a specific position of the PSM does not significantly affect the oscillatory pattern. Such a behaviour is in agreement with experiments which were previously interpreted as ruling out the existence of coupling between cellular oscillators.

This shows that coupling between the PSM oscillators is compatible with all current experimental data. What's more, such coupling could explain phenomena which have hitherto remained obscure. The model could benefit from an extension to 2 or 3 dimensions, to earlier embryonic times (and explain the

way the phase gradient is set up by the spread of the very first wave), and to a strength of coupling set by FGF8 levels (which could then allow to explain the anisotropic effect of FGF8-beads grafts described by Dubrulle et al., 2001). This will be addressed in later studies.

Finally, the model, even though it is based on L-fng activation of Notch signalling (in agreement with biological studies of L-fng), is also compatible with data interpreted as supporting L-fng-mediated repression of Notch signalling.

5 Note added in proof

After this article went to press, J. Lewis proposed a model for the somitogenesis clock, based on negative feedback and transcriptional delays, inspired by the zebrafish but applicable to chick and mouse (Lewis, 2003). Experiments will be required to distinguish between this model and the Lunatic fringe secretion model, but they could differ in their synchronisation properties, and in their abilities to account for the differences in oscillatory patterns in anterior and posterior PSM.

Acknowledgments

I am very grateful to C. Stern for welcoming me to his lab, for the biological supervision of my work, and critical reading of this manuscript, to K. Page for advice on the mathematical aspects, to O. Pourquié for sharing unpublished information, and to J. Stark and R. Callard for helpful comments. This work was funded by a PhD studentship awarded to CoMPLEX by AstraZeneca. We are grateful to AstraZeneca for their support.

References

- Artavanis-Tsakonas S., Rand M., and Lake R. Notch signaling: cell fate control and signal integration in development. *Science*, 284(5415):770–6, 1999. [Abstract](#). 2.2

- Barrantes I., Elia A., Wünsch K., Angelis M. D., Mak T., Rossant J., Conlon R., Gossler A., and de la Pompa J. Interaction between notch signalling and lunatic fringe during somite boundary formation in the mouse. *Curr Biol*, 9(9):470–80, 1999. [Abstract](#). [1](#), [2.2](#)
- Blackshaw S. and Warner A. Low resistance junctions between mesoderm cells during development of trunk muscles. *J Physiol*, 255(1):209–30, 1976. [Abstract](#). [2.2](#)
- Blair S. Notch signaling: Fringe really is a glycosyltransferase. *Curr Biol*, 10(16):R608–12, 2000. [Abstract](#). [1](#), [2.2](#), [3.4](#)
- Caprioli A., Goitsuka R., Pouget C., Dunon D., and Jaffredo T. Expression of notch genes and their ligands during gastrulation in the chicken embryo. *Mech Dev*, 116(1-2):161–4, 2002. [Abstract](#). [2.3](#), [3.4](#)
- Cole S., Levorse J., Tilghman S., and Vogt T. Clock regulatory elements control cyclic expression of lunatic fringe during somitogenesis. *Dev Cell*, 3(1):75–84, 2002. [Abstract](#). [2.2](#), [3.4](#)
- Collier J., Monk N., Maini P., and Lewis J. Pattern formation by lateral inhibition with feedback: a mathematical model of delta-notch intercellular signalling. *J Theor Biol*, 183(4):429–46, 1996. [Abstract](#). [2.2](#)
- Cooke J. A gene that resuscitates a theory—somitogenesis and a molecular oscillator. *Trends Genet*, 14(3):85–8, 1998. [Abstract](#). [1](#), [2.1](#)
- Cooke J. and Zeeman E. A clock and wavefront model for control of the number of repeated structures during animal morphogenesis. *J Theor Biol*, 58(2):455–76, 1976. [Abstract](#). [2](#)
- Dale J., Maroto M., Dequeant M., Malapert P., McGrew M., and Pourquié O. Periodic notch inhibition by lunatic fringe underlies the chick segmentation clock. *Nature*, 421(6920):275–8, 2003. [Abstract](#). [Full text](#). [1](#), [2.2](#), [3.4](#)
- Dubrulle J., McGrew M., and Pourquie O. Fgf signaling controls somite boundary position and regulates segmentation clock control of spatiotemporal hox gene activation. *Cell*, 106(2):219–32, 2001. [Abstract](#). [2](#), [2.1](#), [2.4](#), [4](#)
- Dunwoodie S., Clements M., Sparrow D., Sa X., Conlon R., and Beddington R. Axial skeletal defects caused by mutation in the spondylocostal dysplasia/pudgy gene *dll3* are associated with disruption of the segmentation clock within the presomitic mesoderm. *Development*, 129(7):1795–806, 2002. [Abstract](#). [1](#)
- Eloy-Trinquet S. and Nicolas J. Cell coherence during production of the presomitic mesoderm and somitogenesis in the mouse embryo. *Development*, 129(15):3609–19, 2002. [Abstract](#). [Full text](#). [2.1](#)
- Forsberg H., Crozet F., and Brown N. Waves of mouse lunatic fringe expression, in four-hour cycles at two-hour intervals, precede somite boundary formation. *Curr Biol*, 8(18):1027–30, 1998. [Abstract](#). [1](#), [2.2](#), [3.2](#)
- Freitas C., Rodrigues S., Charrier J., Teillet M., and Palmeirim I. Evidence for medial/lateral specification and positional information within the presomitic mesoderm. *Development*, 128(24):5139–47, 2001. [Abstract](#). [2.3](#)
- Jaeger J. and Goodwin B. A cellular oscillator model for periodic pattern formation. *J Theor Biol*, 213(2):171–81, 2001. [Abstract](#). [1](#)
- Jaeger J. and Goodwin B. Cellular oscillators in animal segmentation. *In Silico Biology*, 2:0010, 2002. [1](#)
- Jiang Y., Aerne B., Smithers L., Haddon C., Ish-Horowicz D., and Lewis J. Notch signalling and the synchronization of the somite segmentation clock. *Nature*, 408(6811):475–9, 2000. [Abstract](#). [Full text](#). [1](#), [2.1](#), [2.2](#)
- Jouve C., Iimura T., and Pourquie O. Onset of the segmentation clock in the chick embryo: evidence

- for oscillations in the somite precursors in the primitive streak. *Development*, 129(5):1107–17, 2002. [Abstract](#). [1](#), [2.1](#), [2.3](#)
- Jouve C., Palmeirim I., Henrique D., Beckers J., Gossler A., Ish-Horowicz D., and Pourquie O. Notch signalling is required for cyclic expression of the hairy-like gene *hes1* in the presomitic mesoderm. *Development*, 127(7):1421–9, 2000. [Abstract](#). [1](#)
- Kaern M., Menzinger M., and Hunding A. Segmentation and somitogenesis derived from phase dynamics in growing oscillatory media. *J Theor Biol*, 207(4):473–93, 2000. [Abstract](#). [Full text](#). [1](#)
- Kepler T. and Elston T. Stochasticity in transcriptional regulation: origins, consequences, and mathematical representations. *Biophys J*, 81(6):3116–36, 2001. [Abstract](#). [2.1](#)
- Kerszberg M. and Wolpert L. A clock and trail model for somite formation, specialization and polarization. *J Theor Biol*, 205(3):505–10, 2000. [Abstract](#). [Full text](#). [2.4](#)
- Keynes R. and Stern C. Mechanisms of vertebrate segmentation. *Development*, 103(3):413–29, 1988. [Abstract](#). [1](#)
- Kulesa P. and Fraser S. Cell dynamics during somite boundary formation revealed by time-lapse analysis. *Science*, 298(5595):991–5, 2002. [Abstract](#). [Full text](#). [2.1](#)
- Lash J. and Ostrovsky D. On the formation of somites. *Dev Biol (N Y 1985)*, 2:547–63, 1986. [Abstract](#). [1](#)
- Lewis J. Autoinhibition with transcriptional delay: a simple mechanism for the zebrafish somitogenesis oscillator. *Curr Biol*, 13(16):1398–408, 2003. [Abstract](#). [5](#)
- McGrew M., Dale J., Fraboulet S., and Pourquie O. The lunatic fringe gene is a target of the molecular clock linked to somite segmentation in avian embryos. *Curr Biol*, 8(17):979–82, 1998. [Abstract](#). [1](#), [3.2](#)
- Morales A., Yasuda Y., and Ish-Horowicz D. Periodic lunatic fringe expression is controlled during segmentation by a cyclic transcriptional enhancer responsive to notch signaling. *Dev Cell*, 3(1):63–74, 2002. [Abstract](#). [2.2](#), [2.3](#), [3.4](#)
- Ozbudak E., Thattai M., Kurtser I., Grossman A., and van Oudenaarden A. Regulation of noise in the expression of a single gene. *Nat Genet*, 31(1):69–73, 2002. [Abstract](#). [Full text](#). [2.1](#)
- Packard D., Zheng R., and Turner D. Somite pattern regulation in the avian segmental plate mesoderm. *Development*, 117(2):779–91, 1993. [Abstract](#). [1](#)
- Palmeirim I., Henrique D., Ish-Horowicz D., and Pourquie O. Avian hairy gene expression identifies a molecular clock linked to vertebrate segmentation and somitogenesis. *Cell*, 91(5):639–48, 1997. [Abstract](#). [1](#), [3.1](#), [3.2](#), [3.3](#), [6](#), [D](#)
- Press W. *Numerical recipes in C : the art of scientific computing*. Cambridge: Cambridge University Press, 1992. [C](#)
- Primmett D., Norris W., Carlson G., Keynes R., and Stern C. Periodic segmental anomalies induced by heat shock in the chick embryo are associated with the cell cycle. *Development*, 105(1):119–30, 1989. [Abstract](#). [1](#), [2](#)
- Prince V., Holley S., Bally-Cuif L., Prabhakaran B., Oates A., Ho R., and Vogt T. Zebrafish lunatic fringe demarcates segmental boundaries. *Mech Dev*, 105(1-2):175–80, 2001. [Abstract](#). [1](#)
- Psychoyos D. and Stern C. Fates and migratory routes of primitive streak cells in the chick embryo. *Development*, 122(5):1523–34, 1996. [Abstract](#). [2.1](#)
- Saga Y. and Takeda H. The making of the somite: molecular events in vertebrate segmentation. *Nat Rev Genet*, 2(11):835–45, 2001. [Abstract](#). [Full text](#). [1](#)
- Schnell S. and Maini P. Clock and induction model for somitogenesis. *Dev Dyn*, 217(4):415–20, 2000. [Abstract](#). [2.2](#)

Selleck M. and Stern C. Fate mapping and cell lineage analysis of hensen’s node in the chick embryo. *Development*, 112(2):615–26, 1991. [Abstract](#). [2.1](#)

Serth K., Schuster-Gossler K., Cordes R., and Gossler A. Transcriptional oscillation of lunatic fringe is essential for somitogenesis. *Genes Dev*, 17(7):912–25, 2003. [Abstract](#). [Full text](#). [1](#), [3.4](#)

Stern C., Fraser S., Keynes R., and Primmatt D. A cell lineage analysis of segmentation in the chick embryo. *Development*, 104 Suppl:231–44, 1988. [Abstract](#). [2.1](#)

Stickney H., Barresi M., and Devoto S. Somite development in zebrafish. *Dev Dyn*, 219(3):287–303, 2000. [Abstract](#). [1](#)

Wu J., Wen L., Zhang W., and Rao Y. The secreted product of xenopus gene lunatic fringe, a vertebrate signaling molecule. *Science*, 273(5273):355–8, 1996. [Abstract](#). [2.2](#)

A Equations for the L-fng secretion model

A system defined by a set of the equations below, without coupling to any neighbours, undergoes oscillations for a wide range of parameters. The mechanism seems to rely primarily on the positive feedback circuit, with the system ”firing” a burst of sensitised Notch and L-fng once a threshold has been reached in Notch and L-fng.

The equations for cell i (the index denotes the antero-posterior position in the PSM) are given by equation [1](#), where l_i is the quantity of Lunatic fringe protein in cell i , n_i the quantity of un-sensitised Notch receptor, n_i^s the quantity of sensitised Notch receptor, $\vartheta_a(i)$ the set of axial (longitudinal) neighbours of oscillator i which are considered to influence it, and $\vartheta_l(i)$ the set of lateral neighbours considered to influence it, with ϵ^a and ϵ^l measuring the respective effects of L-fng in proportion to the cell-autonomous effects. In the case of a one-dimensional chain and nearest-neighbour coupling, neighbours of

cell i this would be cells $i-1$ and $i+1$, except for the first and last oscillators in the chain. α_3 is expected to be small, and corresponds to weak activation of un-sensitised Notch by Delta. The simulations presented below were performed with coupling extending to the 4 nearest neighbours (2 anterior neighbours and 2 posterior neighbours, except for cells close to the borders).

The coupling function used was

$$\epsilon_i^l = \epsilon^l \left(2 + \tanh \left(\frac{-1}{(i/n)^3} + \frac{1}{(1-i/n)^3} \right) \right) \quad (2)$$

with n the number of cells in the simulated PSM.

The dynamics of Notch sensitisation are taken to be linear in both enzyme and substrate as a first simplification. Conditions matching this approximation are saturating un-sensitised Notch or roughly constant levels of un-sensitised Notch.

B Parameters for the L-fng secretion model

Parameters used for simulations are shown in Table [1](#). They were chosen such that the period of the oscillations is about 120 minutes, as in the mouse PSM. Protein concentrations are dimensionless.

The robustness of the model regarding parameter variation was investigated by varying individually each of the parameters in Table [1](#) and equation [2](#), the other parameters and the initial conditions being kept similar (it was too computationally costly to attempt to find ”good” initial conditions for each set of parameters, and the results below thus give a lower bound on robustness). Parameters were deemed satisfactory when a wave spent more than 3 times as much time in the anterior PSM as in the posterior PSM (meaning that oscillations in the posterior PSM are much more synchronous than in the anterior PSM).

The system is least sensitive to parameters governing L-fng (α_0 , α_1 , α_2 , and α_3), the strength of coupling (ϵ^l), and the coupling differential between anterior and posterior PSM (given by equation [2](#)), which all can be individually varied 5-fold around the

$$\begin{aligned}
\frac{dl_i}{dt} &= \alpha_0 \frac{(n_i^s + \alpha_3 n_i)^3}{\alpha_1 + (n_i^s + \alpha_3 n_i)^3} - \alpha_2 l_i \\
\frac{dn_i}{dt} &= \beta_1 - \gamma_1 n_i \left(l_i + \epsilon_i^l \sum_{j \in \vartheta_l(i)} l_j + \epsilon^a \sum_{j \in \vartheta_a(i)} l_j \right) - \beta_2 n_i \\
\frac{dn_i^s}{dt} &= \gamma_1 n_i \left(l_i + \epsilon_i^l \sum_{j \in \vartheta_l(i)} l_j + \epsilon^a \sum_{j \in \vartheta_a(i)} l_j \right) - \gamma_2 n_i^s
\end{aligned} \tag{1}$$

values given in Table 1, with the system preserving its behaviour (the oscillation period can be affected). It is slightly more sensitive to the parameters governing the formation of sensitised Notch and its degradation (respectively γ_1 and γ_2), which can be varied 3-fold around the values given in Table 1. The most sensitive parameters are those governing Notch synthesis and degradation (respectively β_1 and β_2), which can however be varied by 50%.

The parameters in Table 1 correspond to lifetimes of about 3 minutes for L-fng and the sensitised Notch receptor, and of about 64 minutes for the unsensitised Notch receptor. It is normal for the lifetime of the sensitised receptor to be much shorter than that of the sensitised receptor, as it is much more likely to be bound by Delta and cleaved (a process which is not explicitly taken into account by the model). The sensitised receptor is assumed to be about 30 times more efficient at signalling (parameter α_3); thus, if intrinsic stabilities were the same, there should be a 30-fold difference in lifetimes. Since there is only a 20-fold difference, the model assumes that sensitisation makes the receptor more stable than the unsensitised form. Biological data corresponding to these parameters is lacking. The lifetime of L-fng takes into account not only spontaneous or proteolytic degradation, but also diffusion away from the secreting cell, which explains its low value.

Numerical details of the simulations are given in Appendix C.

C Simulation method

Initial conditions were chosen for the system to evolve toward the desired pattern (the Lunatic fringe secretion model currently does not seek to address the

Parameter	Value
α_0	1.08 min ⁻¹
α_1	4.0
α_2	0.217 min ⁻¹
α_3	0.03
β_1	0.0217 min ⁻¹
β_2	0.0108 min ⁻¹
γ_1	15.2 min ⁻¹
γ_2	0.217 min ⁻¹
ϵ^l	0.3

Table 1: Parameters used for simulations.

initiation of oscillations). To account for cell-flow in the PSM, new variables were added at regular intervals at the "posterior" extremity, representing new cells entering the PSM, with fixed initial values (corresponding to the state of an isolated oscillator, 1/3rd of its oscillatory period after its L-fng peak). To account for the blocking of the clock once cells had segmented, derivatives in anterior-most cells were set to 0 once they had been reached by an expression wave, and segmented cells were considered not to influence other cells in the PSM anymore.

Integration was performed with the adaptive-stepsize Runge-Kutta algorithm (Press, 1992), which was implemented in a custom Ada program (source available on request). Simulations comprised 300 cells, and were executed on a Macintosh PowerPC running Mac OS 10.2. Graphs were plotted using gnuplot, converted to animated GIFs using gifsicle, and to QuickTime movies with QuickTimePro.

D Random perturbations

The model presented by J. Lewis as supplemental data to the article by [Palmeirim et al. \(1997\)](#) is a phase model, which does not incorporate any molecular mechanism. On the other hand, the Lunatic fringe secretion model is built on a molecular mechanism. It was thus not obvious which perturbation method to use, as the perturbation magnitudes had to be similar for the comparison to be fair. The method chosen consisted in integrating the equations of the two models by small steps (20 per somitogenesis period), and at each step, deciding at random whether each individual oscillator should have its state variables updated or not (the chance of not updating was 20%). The kind of randomness in oscillator behaviour thus modelled corresponds to oscillators "lagging behind" their normal cycle for short periods of time.